

ITEM NO.	PART NUMBER	DESCRIPTION	QTY.
1	DAJ001	CYLINDER ROD	2
2	DAJ002	REAR PISTON BUSHING	2
3	DAJ003	CYLINDER ROD CAP	2
4	DAJ004	POWER SEATER PISTON	2
5	DAJ006	JACK BODY	1
6	DAJ007	FRONT PISTON BUSHING	2
7	DAJ010	RETAINING PLATE	2
8	DAJ011-1	WEDGE SETTER O-RING	2
9	DAJ011-2	WEDGE SETTER BACKUP RING	2
10	DAJ011-3	REAR BUSHING O-RING	2
11	DAJ011-4	REAR BUSHING BACKUP RING	2
12	DAJ011-5	PISTON ROD O-RING	2
13	DAJ011-6	PISTON ROD BACKUP RING	2
14	DAJ011-7	FRONT BUSHING O-RING	2
15	DAJ011-8	BUSHING BACKUP RING	2
16	DAJ011-9	PISTON U-CUP	2
17	DAJ011-10	PISTON BACKUP RING	2
18	DAJ011-11	ROD BORE O-RING	2
19	DAJ016	NOSE BODY,DAJ5,4"	1
20	DAJ017	WEDGE SETTER,DAJ5,4"	1
21	DAJ018	WEDGE SETTER HOUSING	1
22	DAJ019	RETAINING RING	2
23	DAJ020	HANDLE ASSEMBLY	1
24	DAJ023	GRIPPER HANDLE,DAJ5	1
25	DAJ034	WEDGE SETTER SPRING	2
26	DAJ5GRIP	DAJ5 0.5" STD GRIPPERS	1
27	PLUG-NPT-03750-SQ	PLUG,NPT,3/8",SQ.	2
28	PLUG-NPT-02500-SQ	PLUG,NPT,1/4",SQ.	1
29	SHCS-02500-28-05000	SHCS,.25-28-0.5000 LG	8
30	SHCS-02500-28-07500	SHCS,.25-28-0.7500 LG	4

EXPLODED VIEW ON PAGE 2 OF THIS SALES DRAWING

TOOL CAPACITY (TONS)	SEATER TYPE	STRAND DIAMETER SIZE (IN)	TOOL OPERATION	STROKE (IN)	OIL CAPACITY (CU. IN.)	TOOL EFFECTIVE AREA (SQ. IN.)	MAX PRESSURE (PSI)	WEIGHT (LBS)
20	PISTON	0.50-0.52	DOUBLE ACTING	8.5	54	6.28	10,000	42

THE INFORMATION CONTAINED IN THIS DRAWING IS THE SOLE PROPERTY OF P.T. ATLAS MANUFACTURING LLC. ANY REPRODUCTION IN PART OR WHOLE WITHOUT THE WRITTEN PERMISSION OF P.T. ATLAS MANUFACTURING LLC IS PROHIBITED.

SCALE: 1:2 SHEET SIZE: B SHEET: 1 OF 2

ATLAS
POST-TENSION PRODUCTS

712A W SIMONDS RD SEAGOVILLE, TX 75159

DESCRIPTION:
JACK,DOUBLE ACTING,SINGLE BODY,.5" (SALES DRAWING)

PART NO: **DAJ5** REV **A**

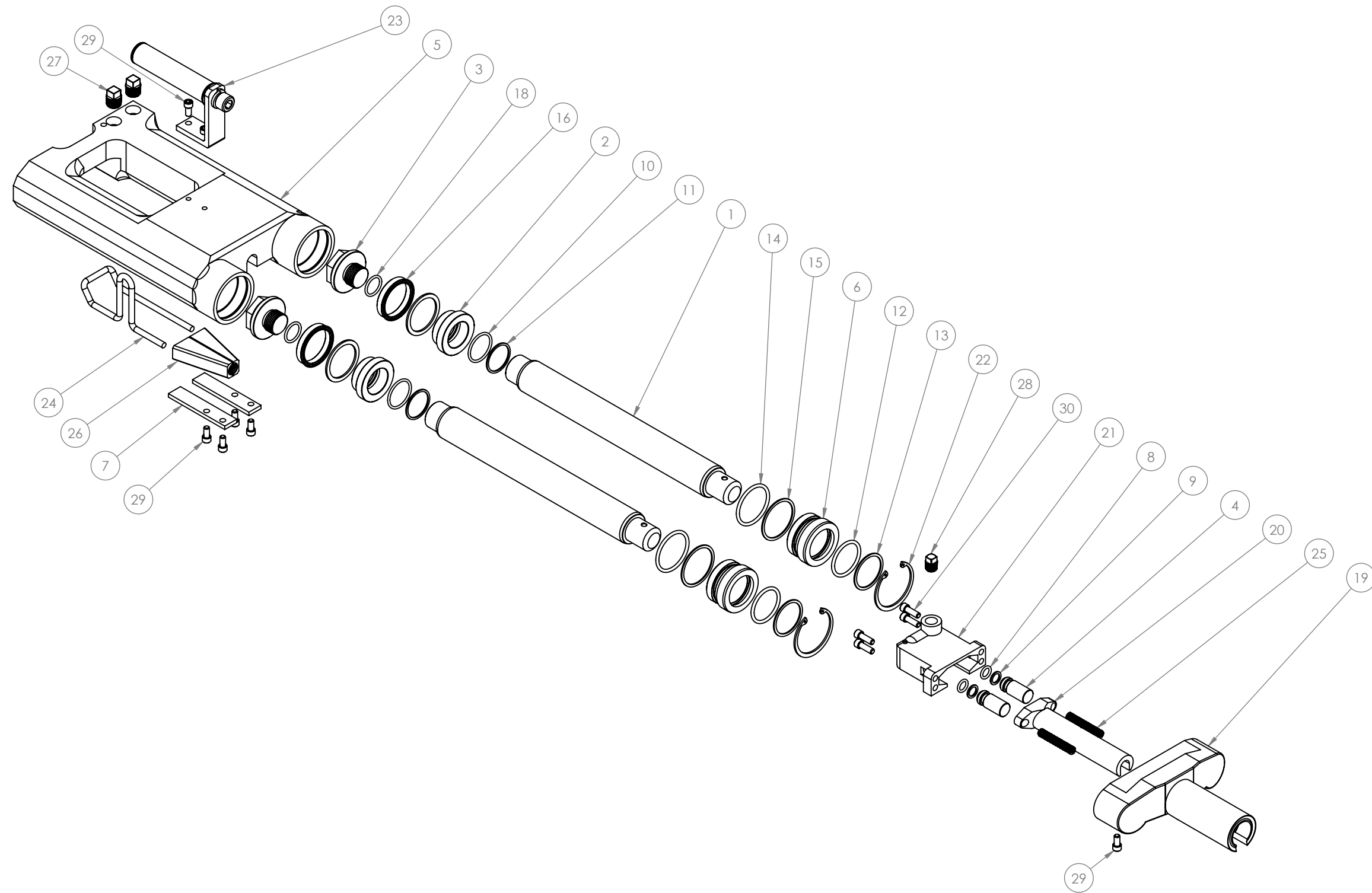

THE INFORMATION CONTAINED IN THIS DRAWING IS THE SOLE PROPERTY OF P.T. ATLAS MANUFACTURING LLC. ANY REPRODUCTION IN PART OR WHOLE WITHOUT THE WRITTEN PERMISSION OF P.T. ATLAS MANUFACTURING LLC IS PROHIBITED

SCALE: 1:5 SHEET SIZE: B SHEET: 2 OF 2

 <p>ATLAS POST-TENSION PRODUCTS</p>	
712A W SIMONDS RD SEAGOVILLE, TX 75159	
DESCRIPTION: JACK, DOUBLE ACTING, SINGLE BODY, .5" (SALES DRAWING)	
PART NO: DAJ5	REV A