

3/4-10 UNC-1B
R.H. THREAD

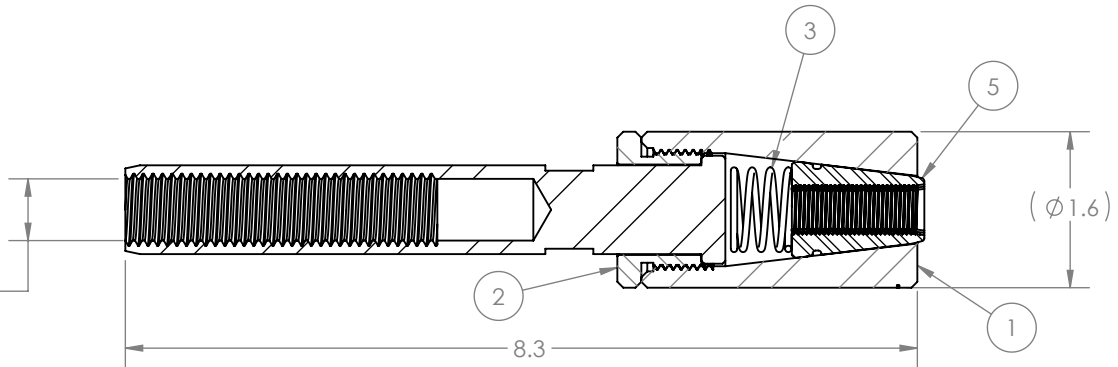

SECTION A-A

ITEM NO.	PART NUMBER	DESCRIPTION	QTY.
1	BC007	L.H. THREADED BODY,0.5"	1
2	BC008	TITAN CAP,0.5"	1
3	BC010	SPRING	1
4	BC011	FEMALE STEM,0.5"	1
5	WG50133ZRM	3PC WEDGE,ZINC PLATED,W/METAL RING	1

TOLERANCES EXCEPT AS NOTED:

DECIMAL: ANGULAR: REF.
X.X = REF. FRACTIONAL: REF.
X.XX = REF.
X.XXX = REF.

MATERIAL: N/A - ASSEMBLY

DRAWN ON: 6/30/2020

DRAWN BY: NM

SCALE: 1:2 SHEET SIZE: A SHEET: 1 OF 1

P.T. ATLAS
MANUFACTURING

712A W SIMONDS RD SEAGOVILLE, TX 75159

DESCRIPTION:
TITAN 0.5" ADJUSTABLE BARRIER CABLE ANCHOR, FEMALE (SALES DRAWING)

PART NO: **BC50AF** REV: **A**